

Technical Datasheet

Product Code: **BAE131701**

Product Description: **Armitage Shanks Sandringham 21 Seat, Cover & Metal Hinges**

Specification

Product Guarantee:	1 Year
Material:	Duroplast
Style:	Modern
Range Name:	Sandringham 21
Shape:	Round
Colour:	White
Barcode:	5017830525875
Packaged Weight (kg):	1.8 kg
Packaged Length (Metre):	0.46
Packaged Width (Metre):	0.383
Packaged Height (Metre):	0.049



Key Features

- Wide-ranging bathroom furniture collection with modern expressive design
- Manufactured from high quality white plastic
- Compatible with Sandringham toilet range
- Alternatively available with plastic hinges
- Complete with all fixings

Technical Drawing

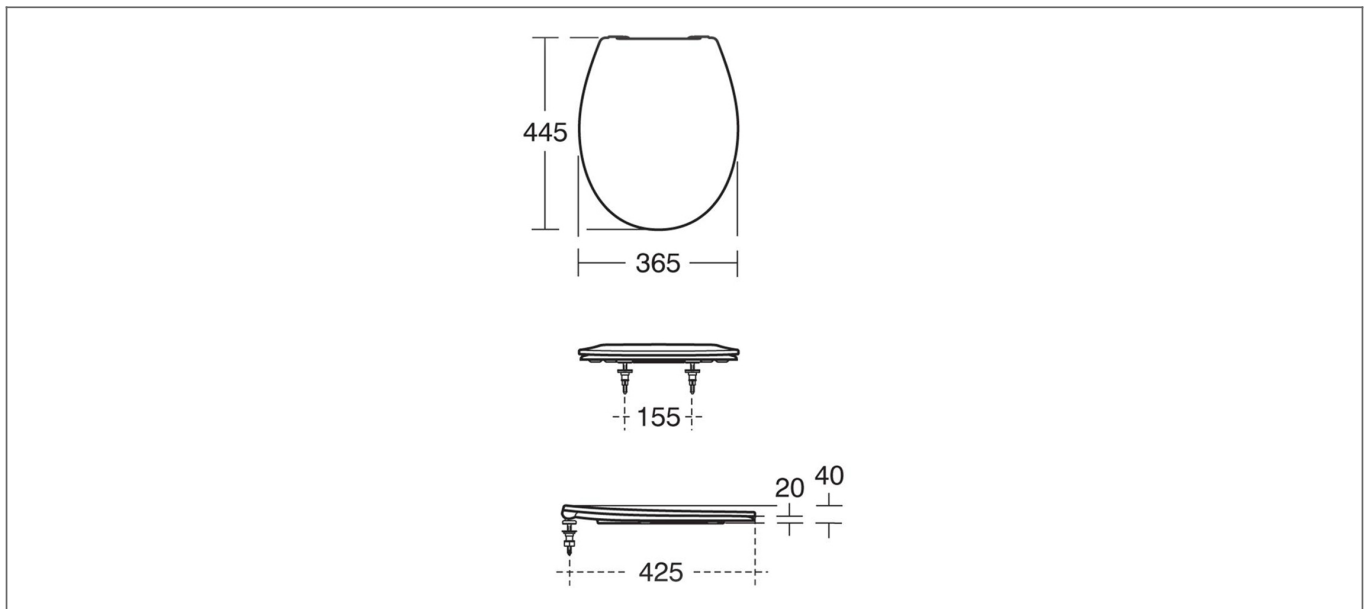

Dimensions: All measurements are in millimetres and are subject to normal manufacturing variations.

Due to a continuing development programme to improve design and performance, we reserve all rights to vary specifications without prior notice. Please note, all accessories are for photographic purposes only.